

# Vista V2 Runway Edge



<p><b>Compliance to standards</b></p>	<p><b>ICAO:</b> International Civil Aviation Organization, Aerodromes, Annex 14, Vol. 1</p> <p><b>IEC TS 61827:</b> Electrical installations for lighting and beaconing of aerodromes. Characteristics of inset and elevated luminaires used on aerodromes and heliports</p>								
<p><b>Application</b></p>	<p>Elevated Bidirectional and omnidirectional Runway EDGE and circling lights indicating the edge of the Airport runway, low and medium intensity according ICAO.</p> <p>The VISTA design has been done in such way as to provide maximum safety. It is a reliable and flexible product, being easy to fit into any kind of infrastructure.</p>								
<p><b>Features</b></p>	<p>Designed and built with simplicity and ease of maintenance in mind. High power LED technology Lightweight, low-energy and environment friendly lighting fitting. Extensive use of aluminium alloys reduces fitting weight and eases handling in the field.</p>								
<p><b>Product Code</b></p>	<p><b>AL - 154 - 06 - WH/YE</b></p> <table data-bbox="555 1682 1423 1832"> <tr> <td>Series Indicator (Airfield Lighting)</td> <td><b>AL</b></td> </tr> <tr> <td>Product Indicator</td> <td><b>154</b></td> </tr> <tr> <td>LEDs Number</td> <td><b>06</b></td> </tr> <tr> <td>LEDs Light Colour (white/yellow)</td> <td><b>WH/YE</b></td> </tr> </table>	Series Indicator (Airfield Lighting)	<b>AL</b>	Product Indicator	<b>154</b>	LEDs Number	<b>06</b>	LEDs Light Colour (white/yellow)	<b>WH/YE</b>
Series Indicator (Airfield Lighting)	<b>AL</b>								
Product Indicator	<b>154</b>								
LEDs Number	<b>06</b>								
LEDs Light Colour (white/yellow)	<b>WH/YE</b>								

<p><b>Description</b></p>	<p><b>Housing</b> - Powder coated aluminium RAL 1004 (aviation yellow) ●</p> <p><b>Dispenser</b> - clear polycarbonate</p> <p><b>Cable gland</b> - nickel plated brass</p> <p><b>Fasteners</b> - stainless steel</p> <p>Light fixtures are provided with anti condensation valve.</p>
<p><b>Environment</b></p>	<p><b>Temperature range:</b> - 55° to +55°</p> <p><b>Degree of protection:</b> IP X8</p> <p><b>Ka tested:</b> Salt mist</p>
<p><b>Mounting</b></p>	<p>Mounted on Ø260mm Base with Frangible Coupling</p> 

**Electrical Characteristics**

**Power consumption:**

Low intensity- 9W  
 Medium intensity- 13W

**Power supply:**

90-230V, 50/60HZ - non dimmable  
 1.4A DC- dimmable: 100%, 30%, 10%

**Types of power supply:**

230V AC directly from mains power supply

**Live** (brown)

**Neutral** (blue)

**Ground** (green/yellow)

1.4A DC power supply from controller with 2 core cable

**V+** (red mark)

**V-** (blue mark)

**Mechanical Characteristics**

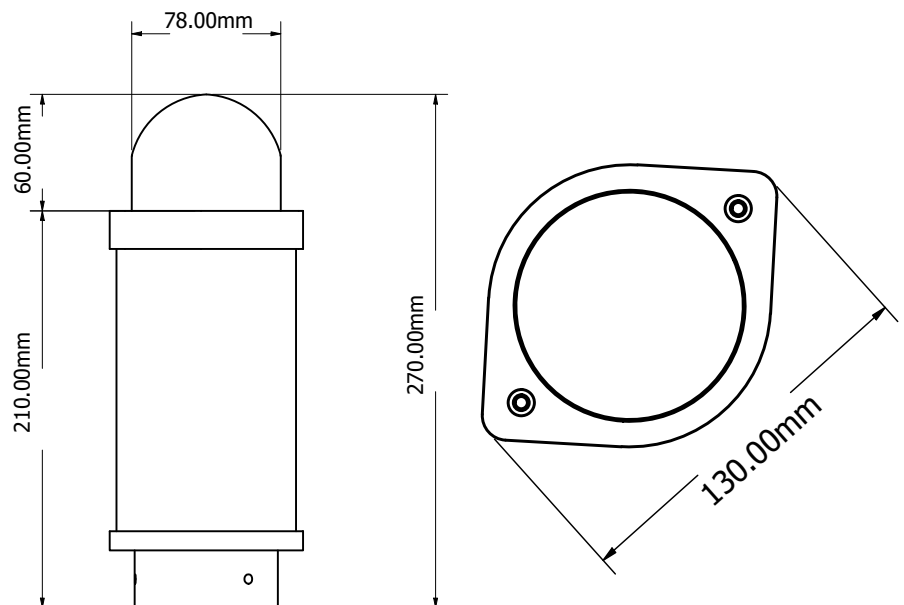

Photometric Characteristics

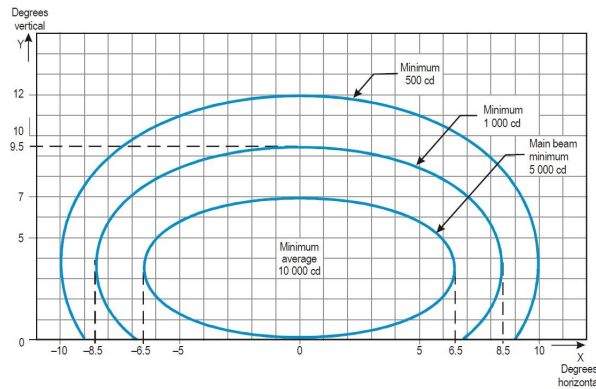

ICAO requirements Annex 14 Vol.1 Fig. A2-10. **WHITE**

Low intensity: 10%  
Average main beam 1000cd  
Medium intensity: 30%  
Average main beam 3000cd

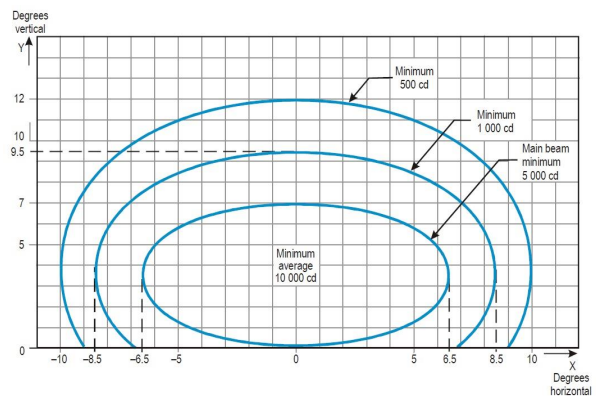

ICAO requirements Annex 14 Vol.1 Fig. A2-10. **YELLOW**

Note for yellow: multiply values by 0.40.

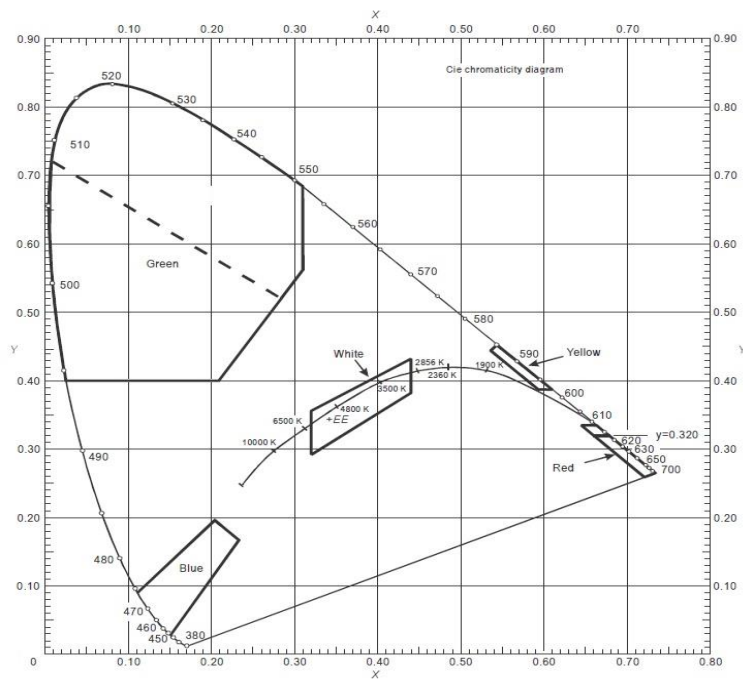

The measured trichromatic coordinates correspond to colour range requirements in:

**ICAO Annex 14 - Aerodromes Vol.1, ig, A1-1b. Colours for aeronautical ground lights**

**Accessory**

To order accessories please call our customer support.

#	NAME - SERIES	PRODUCT CODE	IMAGE
1	Φ32 mm Coupling Tube	AL-100-AX	
2	Frangible Coupling	AL-101-AX	
3	Φ260mm Base Plate	AL-102-AX	
4	Mounting Flange	AL-103-AX	
5	ElectroMax Standard Φ160mm Shallow Base	AL-104-AX	
6	Adapter Ring for 8" Shallow Base	AL-105-AX	
7	Φ160mm Surface Mounted Base	AL-106-AX	
8	IP68 Electrical Junction Box	AL-107-AX	
9	Φ160mm Shallow Base Installation Jig	AL-108-AX	
10	Cable with connector KDC501 EFLA	AL-122-AX	

**als**



**Airfield Lighting Systems UK Ltd**

**Aviation House, Russell Gardens, Wickford, Essex, SS11 8BF, UK**

**[www.airfieldlightingsystems.co.uk](http://www.airfieldlightingsystems.co.uk)**

**[sales@alsukltd.co.uk](mailto:sales@alsukltd.co.uk)**

**Phone +44 (0)1702 547562**