



EAU series LED Unidirectional Elevated Lights

- AL/E Approach Centre Line and Crossbar
- AS/E Approach Side Row
- TH/E Runway Threshold
- TW/E Threshold Wing Bar
- RE/E Runway End
- SB/E Stop Bar



FEATURES

- Adaptable to all kinds of CCRs and ILCMS systems
- PWM digital regulation providing excellent consistency of chromaticity
- Two-tier optical lens bringing excellent luminance consistency
- High pressure precision casting aluminum alloy light body with anti-UV coating
- Built-in surge protection
- Specially designed fail open system suitable for strong magnetism, vibration and other environments

- | | |
|-----------------------------|--------------------------|
| ICAO • Annex 14 Volume I | FAA • AC 150/5345-46 |
| EASA • CS-ADR-DSN | • EB No. 67 |
| CAAC • AC-137-CA-2015-01-R1 | IEC • TS 61827 |
| • AC-137-CA-2015-03-R1 | AENA • DIN/DSEYN/PPT/015 |
| • AC-137-CA-2017-03 | |

TECHNICAL DATA

MECHANICAL

Flange Mounting Holes • 3xØ12 Net Weight • 4.5kg Gross Weight • 4.7kg
Packing Dimensions • 300mm (L) x 240mm (W) x 200mm (H)

ENVIRONMENTAL

Operating Temperature • - 55°C~+55°C Storage Temperature • - 55°C~+85°C Protection Class • IP55 Humidity • 0~100%

ELECTRICAL

Connection • FAA L-823	Rated Input Current • 6.6A	Power Factor • >0.95
Emission • IEC 61000-6-4	Immunity • IEC 61000-6-2	Service Life • LED useful lamp life > 80000h
Approach Centre Line and Crossbar • 35VA	Approach Side Row • 22VA	Runway Threshold • 25.5VA
Threshold Wing bar • 25.5VA	Runway End • 9VA	Stop Bar • 6VA

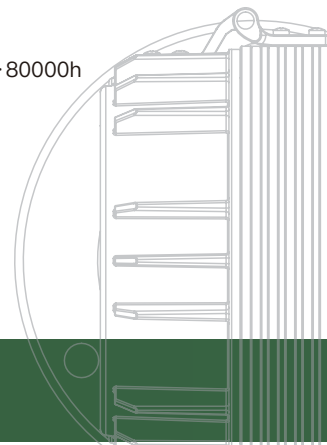

als



EAU Series



COMPONENTS

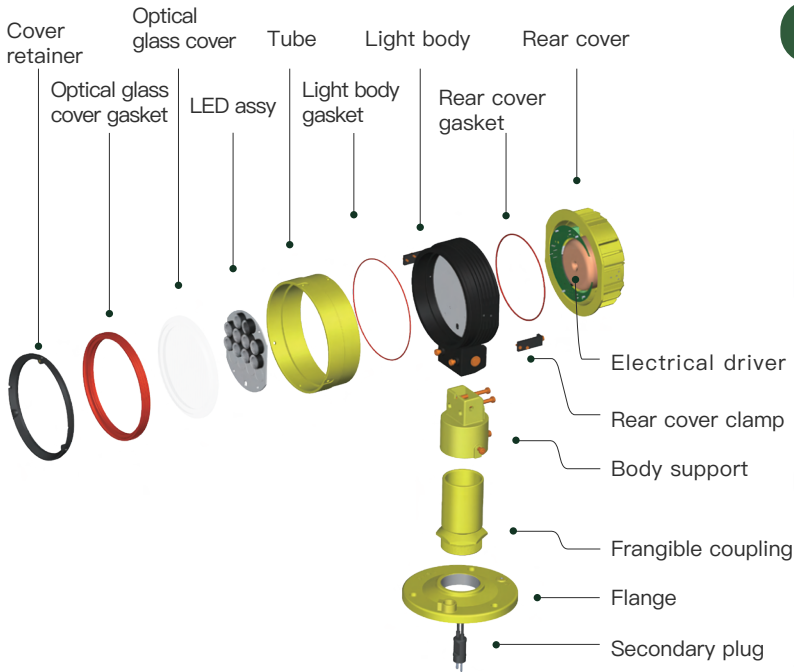

DIMENSIONS

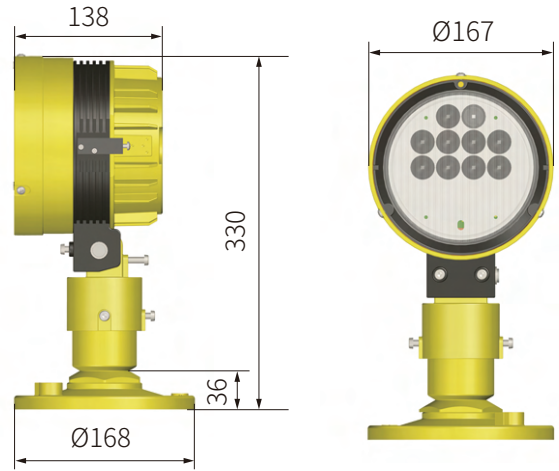

ACCESSORIES

- ◎ Flange (168mm OD)
- ◎ Flange (240mm OD)
- ◎ Flange (300mm OD)
- ◎ L-823 receptacle
- ◎ 2 inches frangible coupling type A (pole mounted)
- ◎ 2 inches frangible coupling type B (ground mounted)

PHOTOMETRICS

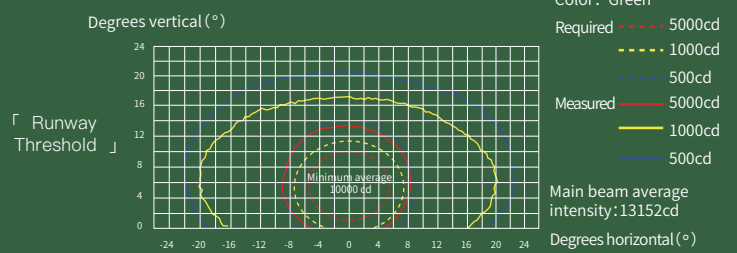
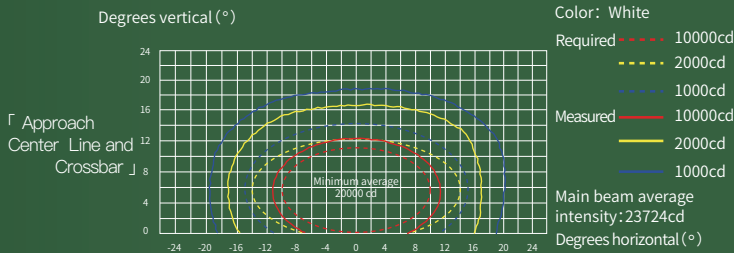

als



Airfield Lighting Systems (UK) Limited
Aviation House, Russell Gardens,
Wickford, Essex, SS11 8BF UK

Tel: +44 1702 547562
Email: sales@alsukltd.co.uk
Website: www.alsukltd.co.uk

ORDERING CODES

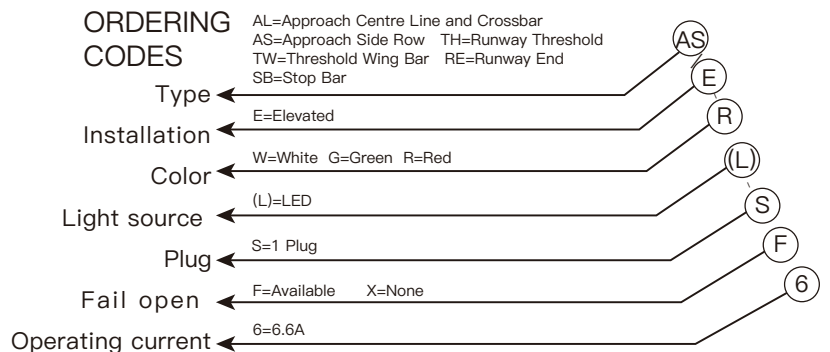

* Accessories should be ordered separately