



## Aircraft Stand Manoeuvring Guidance Lights

- SBS/IN-R Unidirectional Red
- TE/IN-Y Omnidirectional Yellow
- TE/IN-R Omnidirectional Red

## FEATURES

- Low protrusion of 6 mm above ground level
- Adaptable to all kinds of CCRs and ILCMS systems
- PWM digital regulation providing excellent consistency of chromaticity
- Aluminum alloy forged top cover with hardened surface and corrosion resistant treatment
- Built-in surge protection
- Specially designed fail open system suitable for strong magnetism, vibration and other environments
- Available for series or parallel power supply

ICAO • Annex 14 Volume I  
 EASA • CS-ADR-DSN  
 IEC • TS 61827  
 AENA • DIN/DSEYN/PPT/018  
 • DIN/DSEYN/PPT/019

FAA • AC 150/5345-46  
 • EB No. 67  
 CAAC • AC-137-CA-2015-01-R1  
 • AC-137-CA-2015-03-R1

## TECHNICAL DATA

### MECHANICAL

Mounting • 2 x M10 bolts      Static Load Resistance •  $\geq 18t$       Net Weight • 3.5kg      Gross Weight • 3.7kg  
 Packing Dimensions • 253mm (L) x 223mm (W) x 107mm (H)

### ENVIRONMENTAL

Operating Temperature •  $-55^{\circ}\text{C} \sim +55^{\circ}\text{C}$       Storage Temperature •  $-55^{\circ}\text{C} \sim +85^{\circ}\text{C}$       Protection Class • IP68      Humidity • 0-100%

### ELECTRICAL

Connection • FAA L-823      Service Life • LED useful lamp life  $> 80000\text{h}$   
 Series Power Supply • 6.6A/2.2A      Power Factor @6.6A/2.2A •  $> 0.95$       Power Consumption @6.6A/2.2A • 9VA (SBS/TE-Y) • 5.5VA (TE-R)  
 Parallel Power Supply • 85~275VAC      Power Factor @230VAC •  $> 0.75$       Power Consumption @230VAC • 5VA(SBS/TE-Y) • 3.5VA (TE-R)  
 Immunity • IEC 61000-6-2      Emission • IEC 61000-6-4

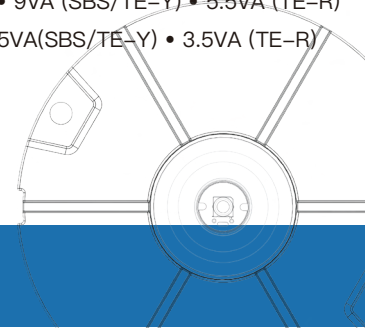



## COMPONENTS

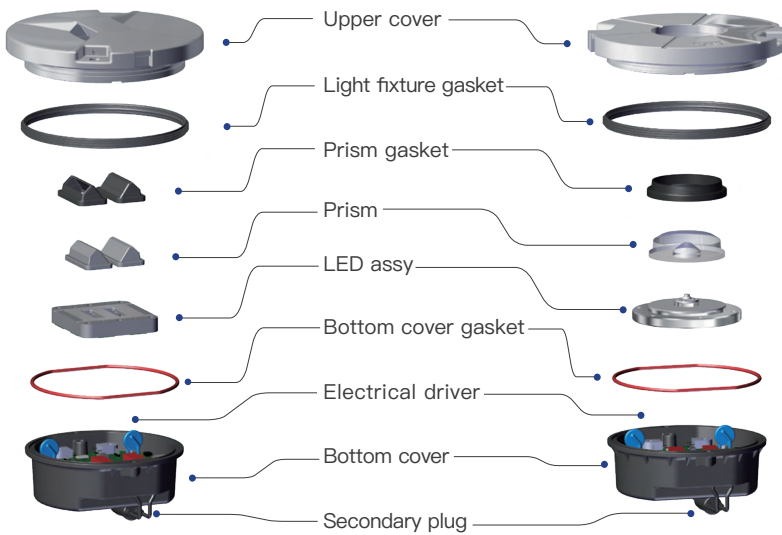

## DIMENSIONS

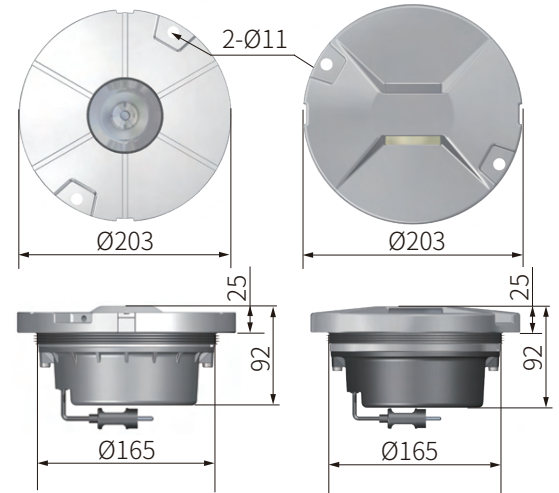

## ACCESSORIES

\* The electrical drivers used for series and parallel power supply are different

- ⊙ 8 inches shallow base assy (bottom entry/side entry)
- ⊙ 12 inches deep base assy
- ⊙ 12-8 inches adapter ring assy
- ⊙ L-823 receptacle
- ⊙ 8 inches light fixture handle

## PHOTOMETRICS

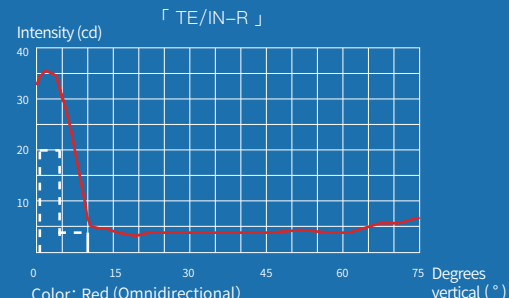
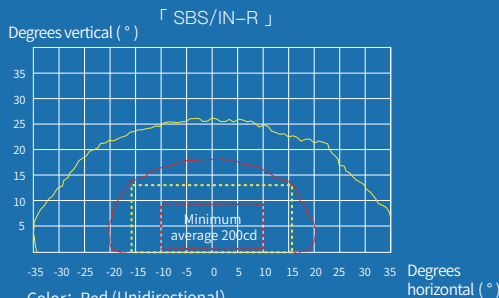
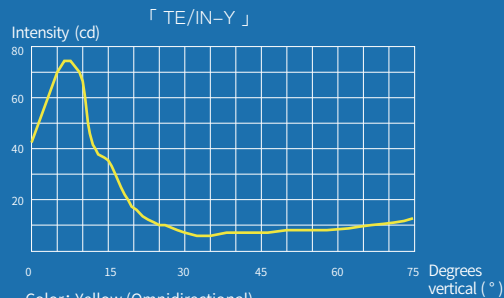

Airfield Lighting Systems (UK) Limited  
 Aviation House, Russell Gardens, Wickford,  
 Essex, SS11 8BF UK

Tel: +44 1702 547562  
 Email: sales@alsukltd.co.uk  
 Website: www.alsukltd.co.uk

## ORDERING CODES

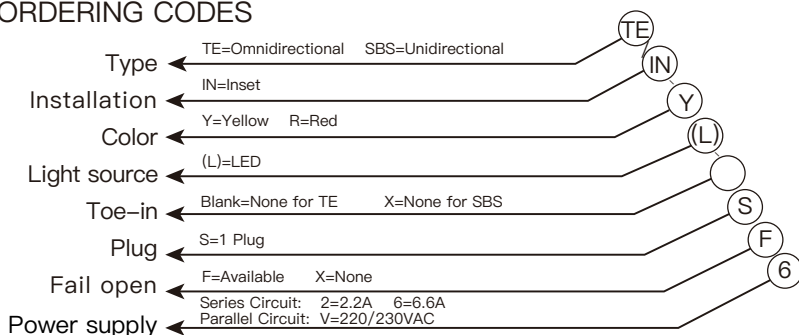

\* Accessories should be ordered separately